

REINHOLD ENVIRONMENTAL Ltd.



**2015 APC Round Table
& Expo Presentation**

July 13 & 14, 2015, in Atlanta, GA / Hosted by Southern Company

All presentations posted on this website are copyrighted by Reinhold Environmental, Ltd (RE). Any unauthorized downloading, attempts to modify or to incorporate into other presentations, link to other websites, or obtain copies for any other uses than the training of attendees to RE's Conferences is expressly prohibited, unless approved in writing by RE or the original presenter. RE does not assume any liability for the accuracy or contents of any materials contained in this library which were presented and/or created by persons who were not employees of RE.

ESP Power Supply Panel

Chairman: Gary Reinhold, REC

Agenda

- Scope for panel discussion – 5 minutes
- Introduction of Panelists – 5 minutes
- Chairman's questions to panelists – 40 min.
- Audience question and answer period – 40 min.

Scope for ESP Panel Discussion

- A candid technical discussion of the pros and cons of the currently available ESP Power supply technologies which might be used in the upgrade of an aging ESP.
- Place an emphasis on the most important criteria in a MATS and proposed Clean Power Plan regulatory environment, e.g. consistently meeting regulatory limits, reliability and minimizing power cannibalization.

Scope for ESP Panel Discussion

This panel will discuss the pros and cons of :

- Three phase 60 Hz TRs
- Mid-frequency (400 Hz)TRs
- High-frequency (20 KHz) switch mode power supplies
- Hybrid systems

Agenda

- Scope for panel discussion – 5 minutes
- Introduction of Panelists – 5 minutes
- Chairman's questions to panelists – 40 min.
- Audience question and answer period – 40 min.

Introduction of Panelists

Suppliers

- David Johnston-B&W-Three phase 60 Hz TRs
- Paul Ford-Redkoh-Mid frequency TRs
- Fran Skovran-NWL-High frequency SMPS
- David Jackson-Stock Equipment-High frequency centralized control SMPS

Users

- John Walker-REC (formerly Duke)-Three phase 60 hz
- Jerry Klemm-Southern Company-High frequency
- Scott Thomas-Duke-Hybrid (High frequency/60 Hz TRs)

Agenda

- Scope for panel discussion – 5 minutes
- Introduction of Panelists – 5 minutes
- Chairman's questions to panelists – 40 min.
- Audience question and answer period – 40 min.

Chairman's Questions

David Johnston:

B&W has supplied over 800 three phase 60 Hz TRs internationally and has installed some within the United States. Given that these transformers are more expensive, weigh more and are larger, why are they being requested instead of the other types?

The Single-Phase Power Supply

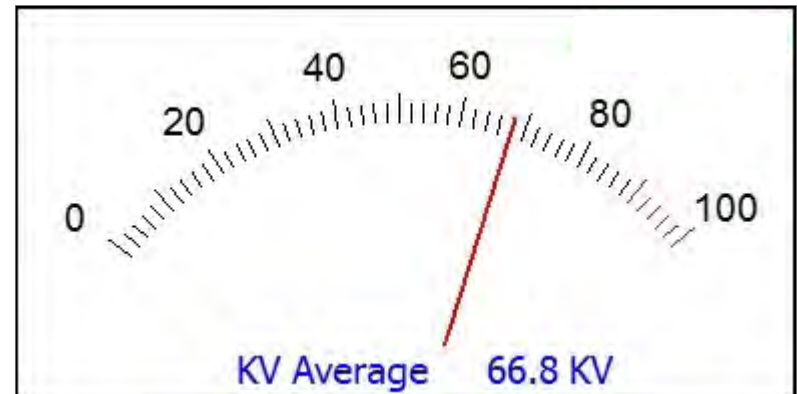
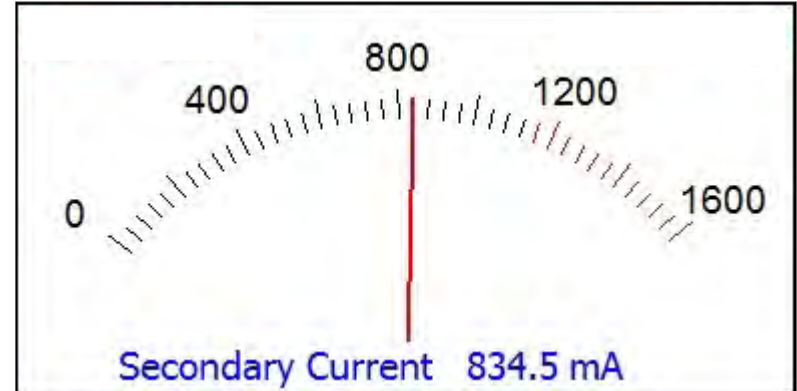
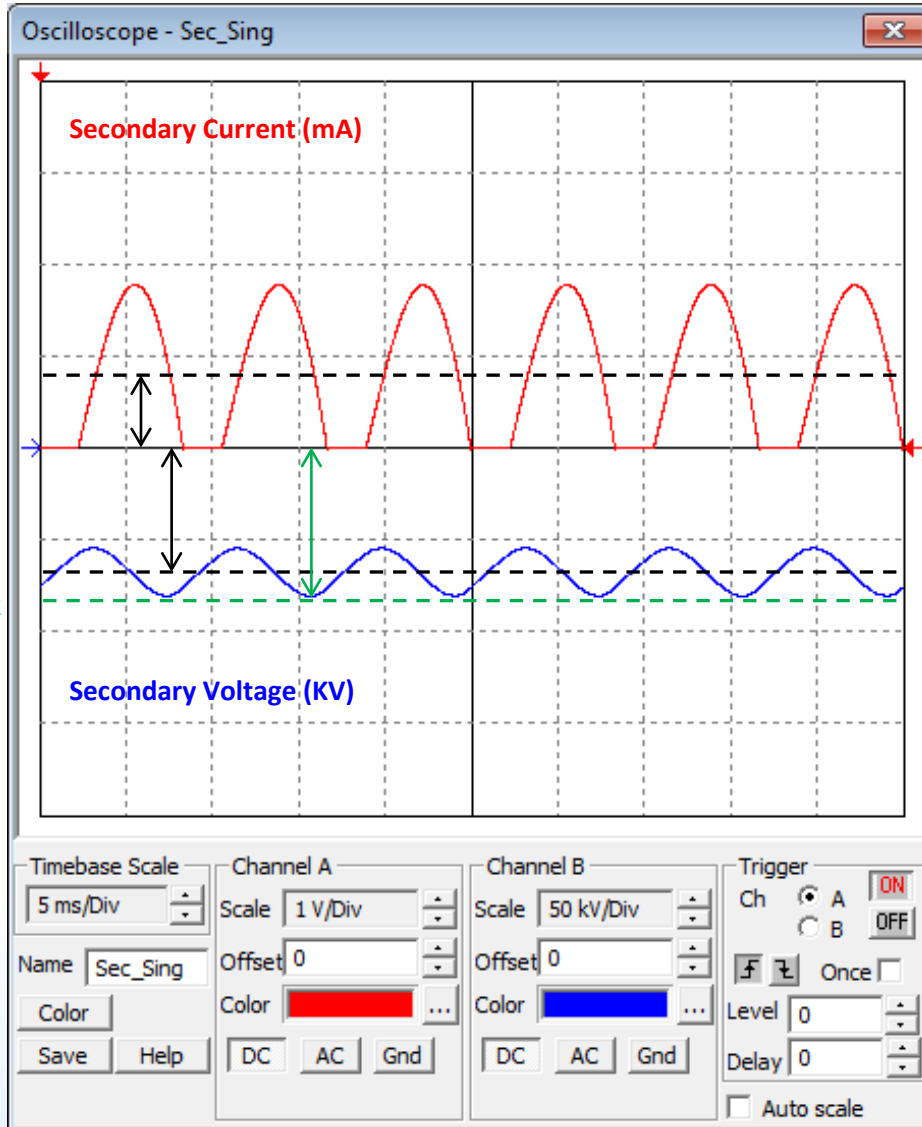

Peak to Avg. Voltage Ratio = 1.4

$\omega \approx \beta * 67 \text{ KV Avg.} * 80 \text{ KV Peak}$

The 3-Phase Power Supply Provides a Low Ripple Output Like Switch Mode

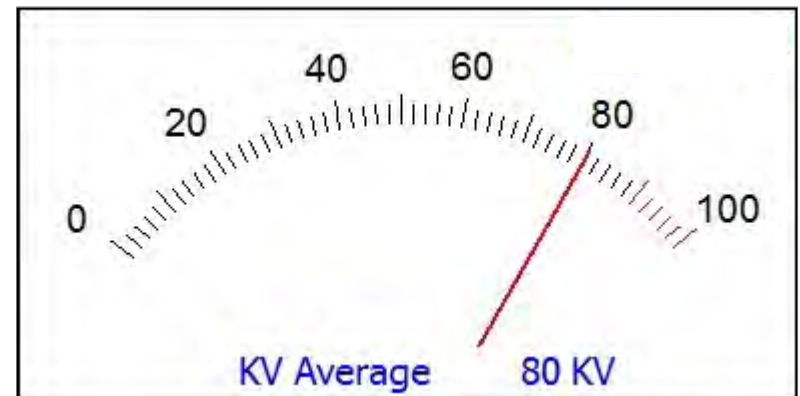
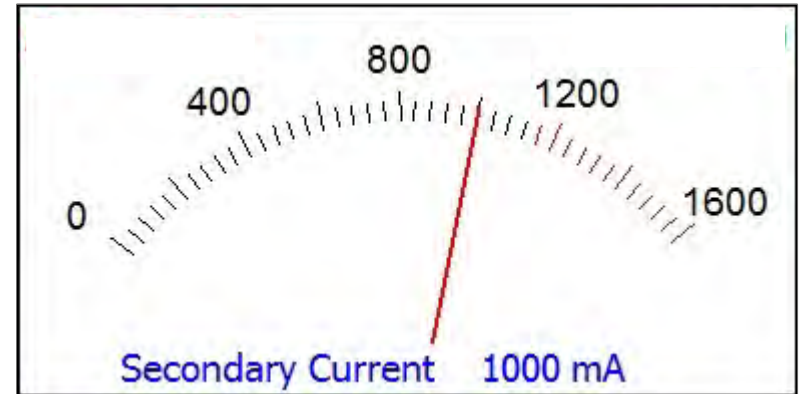
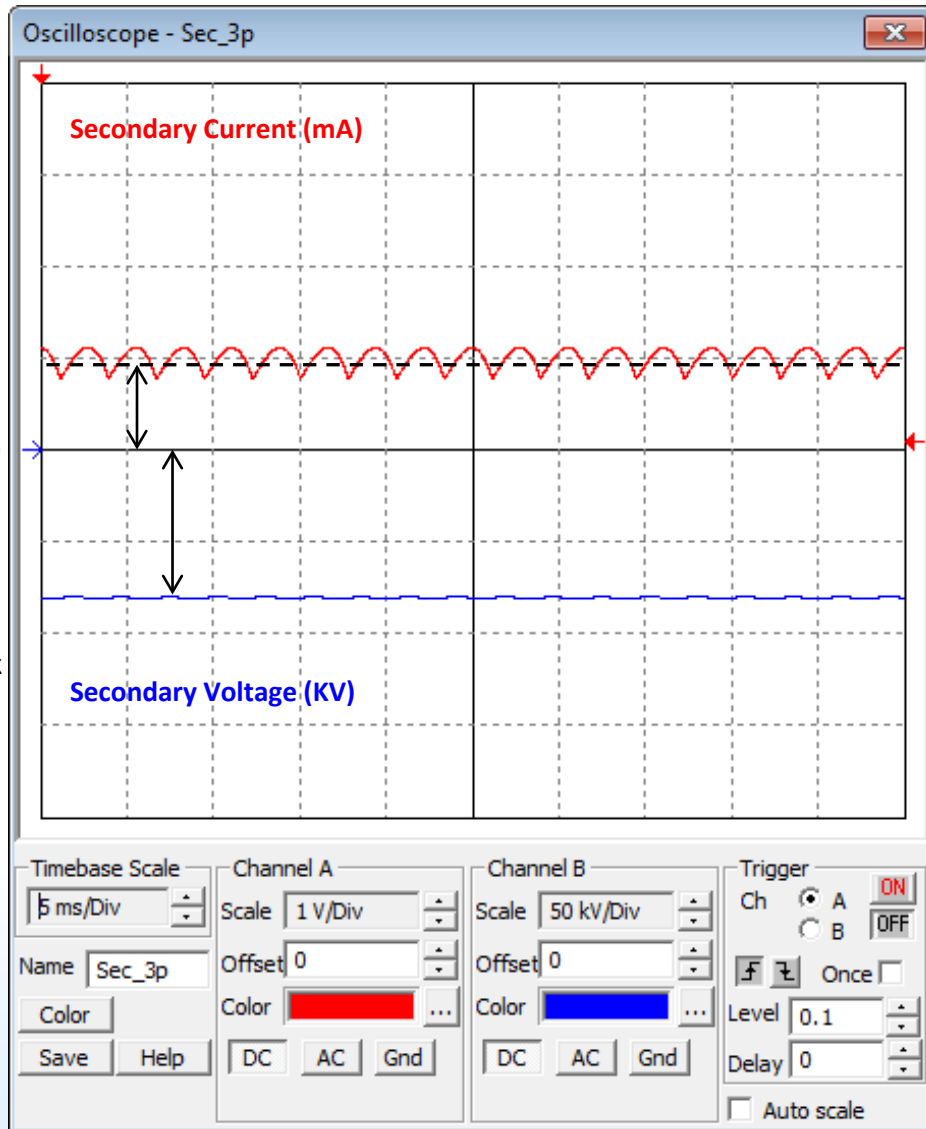

Peak to Avg. Voltage Ratio ≤ 1.1

$\omega \approx \beta * 80 \text{ KV Avg.} * 80 \text{ KV Peak}$

The 3-Phase is the Only Configuration That Has a True 3-Phase Output

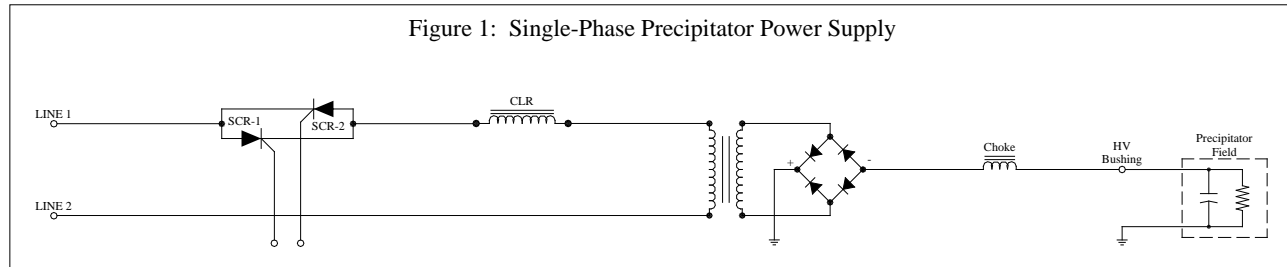

Single-Phase
Input

Single-Phase
Output from
Transformer

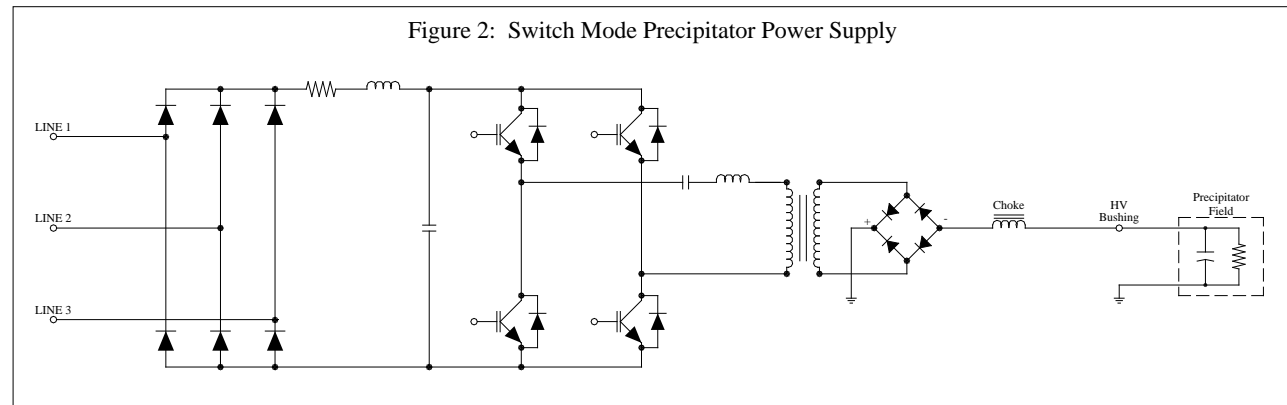

3-Phase Input

Single-Phase
Output from
Transformer

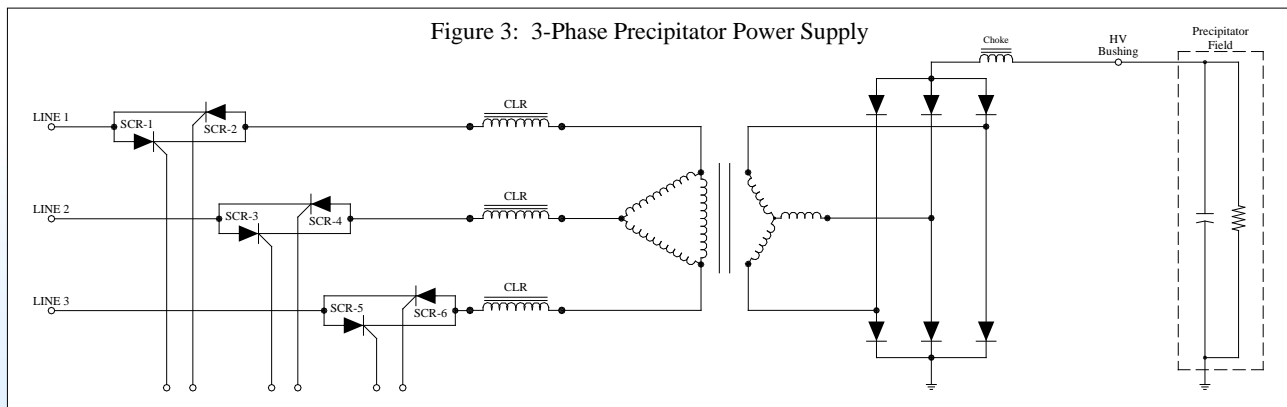

3-Phase Input

3-Phase
Output from
Transformer



Chairman's Questions

John Walker:

At Duke's Wabash River Plant you did some testing of B&W's three phase 60 Hz supplies as an inexpensive way to improve ESP performance without changing out the discharge electrodes or plates. What were your conclusions from the test results?

Chairman's Questions

Paul Ford:

Can you discuss the mid frequency project you are doing with PacifiCorp at Jim Bridger and why they chose that option?

Transitioning from SCR to IGBT Controlled Power Supplies for ESP

Unit 1	kV SCR	kV IGBT	MA SCR	MA IGBT	SPM SCR	SPM IGBT
TR2A	40	39	580	1227	28	50
TR2B	38	38	440	843	50	30
TR2C	36	39	570	683	50	28
TR2D	38	37	570	585	27	27
TR2E	37	37	920	1190	3	18

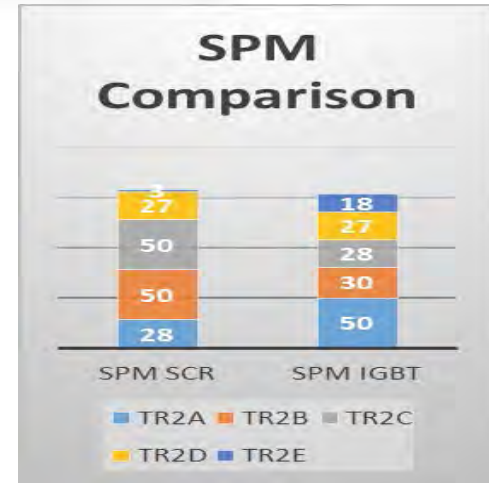
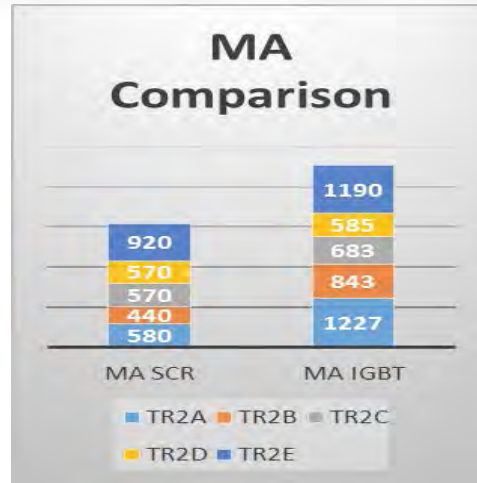
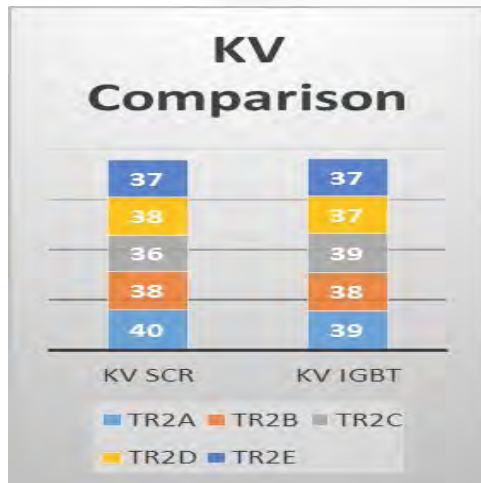

Paul Ford



PRECIPITATOR CONTROLS SPECIALISTS

Original SCR Control Cabinet



PRECIPITATOR CONTROLS SPECIALISTS

Upgraded Control Cabinet



PRECIPITATOR CONTROLS SPECIALISTS

Chairman's Questions

Fran Skovran:

Some initial criticisms of High Frequency SMPS were that they were too small to replace existing TRs without sectionalization and that they were unreliable. Have there been improvements in the size and reliability of the High Frequency SMPS over the past several years and what lessons have been learned from the field?

Chairman's Questions

Gerry Klemm:

Southern Company has installed many high frequency SMPS over the past several years. How is your post MATS performance of these units and have there been any changes in your thinking as to most important criteria?

Chairman's Questions

David Jackson:

Stock Equipment provides standard 60 Hz TRs and a hybrid High Frequency SMPS with centralized controls.

What is your current experience as to the domestic demand for these two types of supplies?

Chairman's Questions

Scott Thomas: At Belews Creek you are keeping your existing weighted wire discharge electrodes and plate spacing. You have upgraded some of your inlet and second fields with High Frequency SMPS and kept your standard 60 Hz TRs in the remaining fields. What is your thought process and experience to date with this hybrid approach?

Agenda

- Scope for panel discussion – 5 minutes
- Introduction of Panelists – 5 minutes
- Chairman's questions to panelists – 40 min.
- Audience question and answer period – 40 min.

Audience Questions

ESP Power Supply Panel

Thank You!